

MODULAR CONCEPT

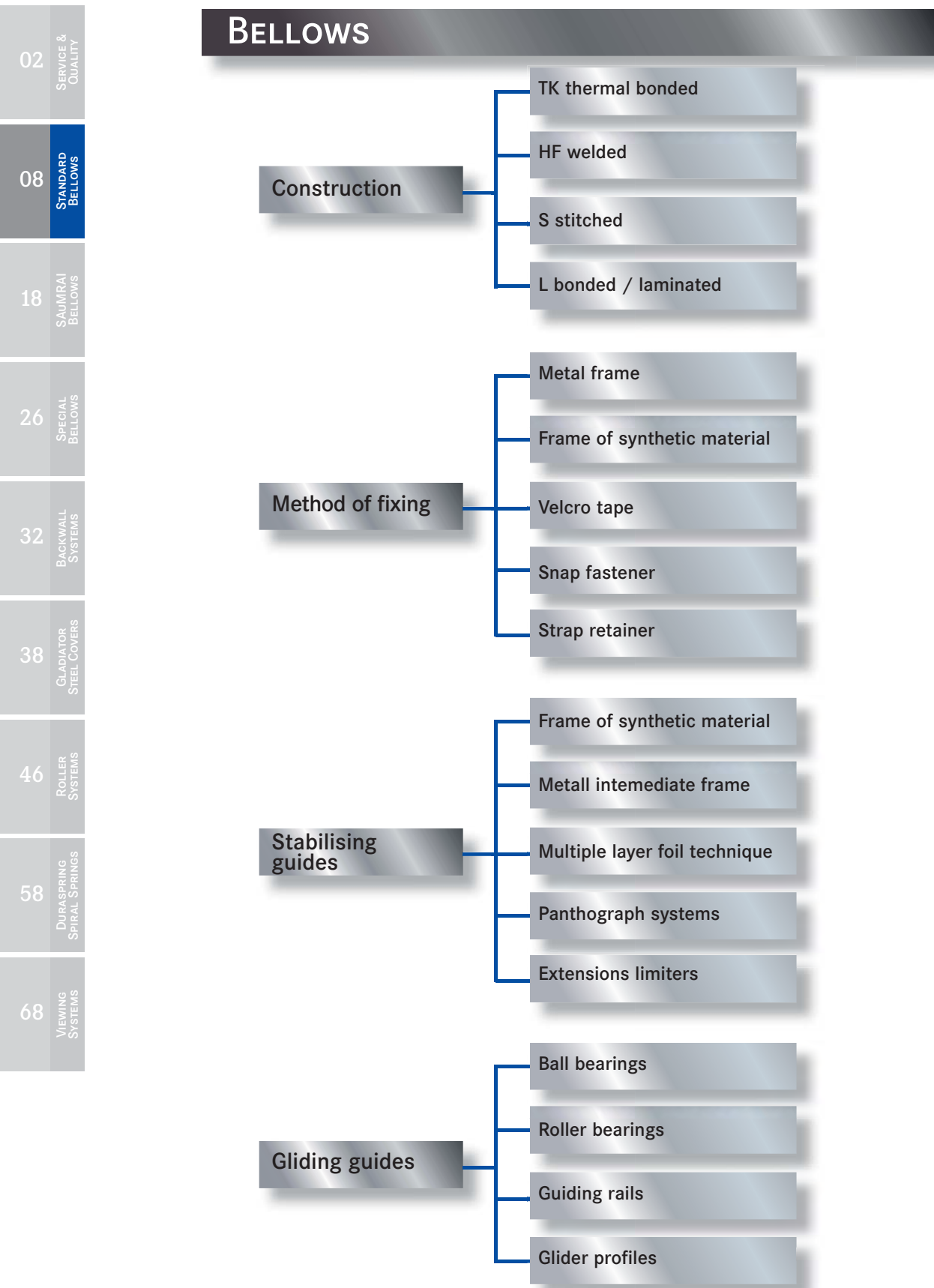

ELASTIC BELLOWS

ELASTIC Bellows are commonly used for protecting machines and devices against debris and chips. They are also used in many variations for safety at work.

The experience resulting from the production of many thousands of ELASTIC Bellows and their use in working applications has been converted directly into product improvements, new developments, and enhanced product lifetime.

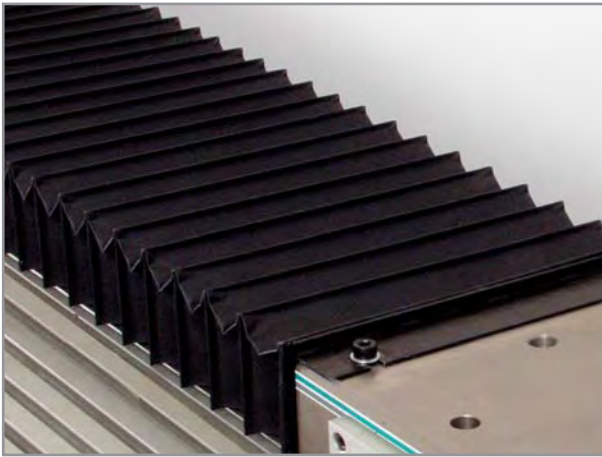

U shape ELASTIC Bellows mounted with metal frame

Constantly growing demands for ever greater machine speeds and ever lower noise emissions are consistently implemented by our engineers.

- Optimal use of space
- Machine size reduced with special materials and space saving designs
- Complete systems - bellows integrated in the machine's rear wall covering, complete with guides and mounting devices
- High temperature resistant materials up to 600°C for laser, plasma and welding applications
- Special designs with antistatic surfaces for medical technology and clean room conditions
- Special designs for HSC applications
- Impermeability to coolants

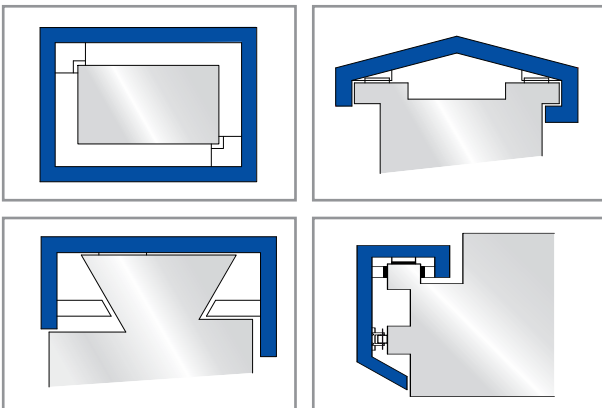

Types



Bellows for elevating platform

Design

ELASTIC Bellows are a series of products with many combinations and options. Their basic components, materials, forms, processing methods, and dimensions are easily adaptable. For applications such as elevating platforms, bellows can be produced with up to 30 square meters. All ELASTIC Bellows may be deployed horizontally or vertically. They can be easily attached to the machine with metal frames or Velcro tapes. Efficient glider profiles and roller or ball bearings improve quiet running and also serve to extend life cycles and minimise friction during HSC applications as well.



Glider profiles

SERVICE & QUALITY 02

STANDARD BELLOWS 09

SAUWRAI BELLOWS 18

SPECIAL BELLOWS 26

BACKWALL SYSTEMS 32

GLADIATOR STEEL COVERS 38

ROLLER SYSTEMS 46

DURASPRING SPIRAL SPRINGS 58

VIEWING SYSTEMS 68

ELASTIC BELLOWS



Roller bearing

During high starting accelerations extension limiters help to reduce the load on the first folds, even out the extension, and stabilise travelling.

Material

Standard materials are black, but also signal colours such as yellow or white materials for medical applications are available.

The material is selected from a large range of products to match the intended use of the ELASTIC Bellows.

Also self extinguishing heat resisting materials under the UL 94 standard are available.

Design of ELASTIC Bellows

The essential component of the ELASTIC Bellows is a stabilising PVC frame inside every fold that lends the ELASTIC Bellows high dimensional stability. Reversion to the original shape is therefore assured after direct impacts.

Beside PVC frames PP and Polyamide can be offered as an alternative material for the support frames.

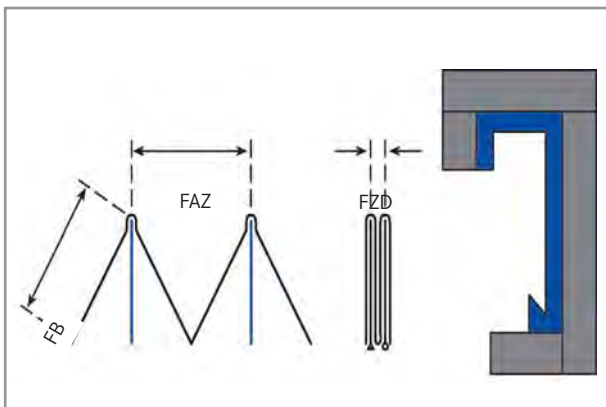

Bellows construction with stabilising PVC frame

ELASTIC bellows are available in the following versions depending on how their frames are permanently joined to the outer fold material:

- thermal bonded version
- HF welded version
- sewn version

Thermal bonded version

Under the action of heat and a specially developed flux permanent bonding is achieved between the inner PVC frame and the outer fold material.

Thermal bonded ELASTIC Bellows are maintenance free, water and dust proof as well as oil resistant and, to a certain extent, acid resistant.

HF welded version

This type is used particularly for the production of large, shutter type ELASTIC Bellows.

High frequency welding is used to join the PVC frames with the outer bellow material for a perfect shape and a regular overall appearance.

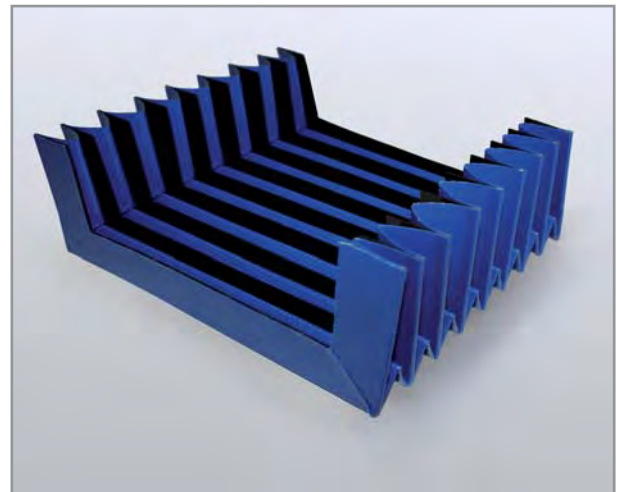

U shape Bellows with stabilising PVC frame

Sewn version

The sewn version consists primarily of high temperature materials. Strong fabrics therefore assure a long lasting solution even under extreme loads.

Mounting

ELASTIC Bellows can be easily mounted on machines and devices with components such as:

- frames of metal or synthetic material attached to both ends and designed to customer specifications
- Velcro tape, easy and fast, maintenance friendly
- clip fasteners combined with metal frames

ELASTIC BELLOWS

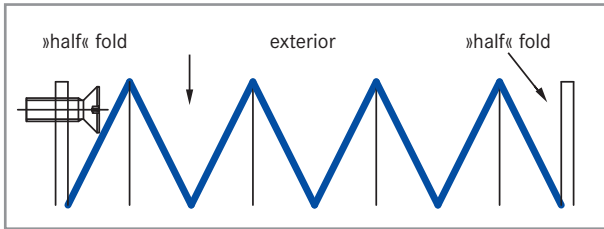

End flanges can also be mounted from the outside

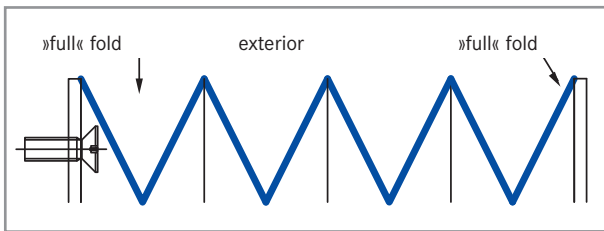

End flanges can be mounted only from the inside

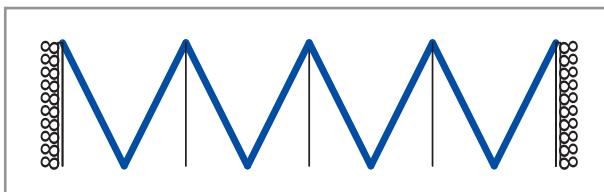

Mounted with velcro tape, both sides full fold

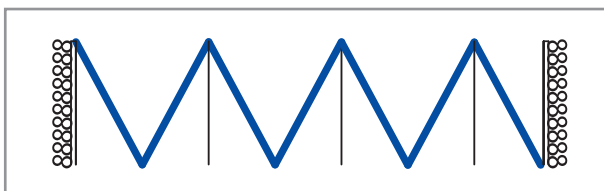

Mounting with velcro tape, one side half, one side full fold

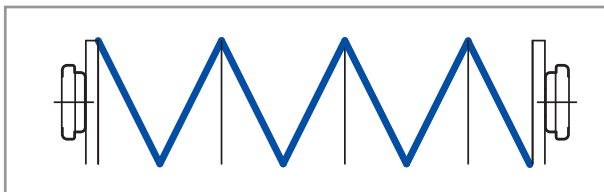

Mounted with clip fasteners, both sides full fold

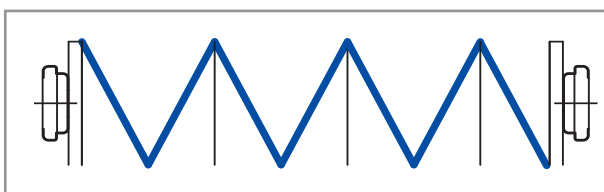

Mounted with clip fasteners, one side half, one side full fold

Legend and formulae for calculation

| | |
|-----|-------------------------------|
| FB | Width of the fold |
| FZ | Number of folds |
| FZD | Compression per fold |
| FAZ | Extension per fold |
| BE | Width of the terminal fixture |
| AZ | Maximum extension |
| ZD | Minimum compression |

Formulae for calculation

| | |
|----|------------------------------------|
| ZD | AZ-Hub |
| FZ | $\frac{AZ}{FAZ}$ |
| ZD | $\frac{(AZ \times FZD) + BE}{FAZ}$ |
| AZ | $\frac{(ZD - BE) \times FAZ}{FZD}$ |

| FB (mm) | FAZ (mm) | FZD* (mm) |
|---------|----------|-----------|
| 15 | 22 | 3 - 5 |
| 17,5 | 24 | 3 - 5 |
| 20 | 30 | 3 - 5 |
| 25 | 38 | 3 - 5 |
| 30 | 48 | 3 - 5 |
| 35 | 55 | 3 - 5 |
| 40 | 65 | 3 - 5 |
| 45 | 75 | 3 - 5 |
| 50 | 85 | 3 - 5 |

* depending on material



Rear view of complete solution, ELASTIC Bellows used for X axis

LAMINAT BELLOWS

LAMINAT Bellows are characterized by several layers of foil bonded together. The LAMINAT bellows are used where flexible designs and inherent rigidity are important.



LAMINAT Bellows with octagon section and strap retainer

Application

LAMINAT Bellows are nowadays deployed in spindle-type lifting gear, for cameras, measuring and music instruments as well as for medicine and food technologies. They are used to protect columns, spindles and shafts.

All LAMINAT Bellows can be used vertically or horizontally, including hybrid forms. They allow smooth and very quiet running properties.

The surface structure and the regularity of contours present an appealing overall appearance.



Perfect surface of LAMINAT Bellows for medical devices

LAMINAT Bellows are not suited to applications with high temperatures and humidity. If these criteria should be relevant, models from our other lines may be considered, such as Rubber Disk Bellows or Fabric Bellows (see Special Bellows section).

Material

LAMINAT Bellows can be adapted through the choice of basic components, materials, shape, colours, and dimensions. The basic design concept of the LAMINAT Bellows is based on a two-component material.

A manufacturing technique developed to perfection combines the outer material requested by the customer with the appropriate interior material selected by the HEMA designer. For additional stability PVC or metal frames can be added.

Maintenance

A further benefit of these bellows comes in the form of their segmented design. Damaged parts of the LAMINAT Bellows can be easily replaced, reducing significantly the costs for maintenance.

Design

Like the ELASTIC Bellows LAMINAT Bellows can also be designed and produced in a variety of forms.

LAMINAT Bellows are primarily used to cover and protect columns and spindles. Rectangular, hexagonal, octagonal and twelve-sided sections are available as well as roof and inclined shapes and Venetian blind style standards.



LAMINAT Bellows with intermediate frames

LAMINAT BELLOWS

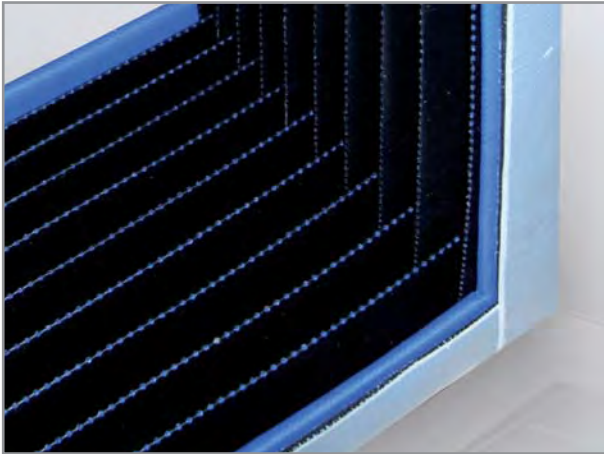

LAMINAT Bellows, view of interior

LAMINAT Bellows are available as split designs as well. The split type facilitates bellow replacement and maintenance, and so is perfect as a retrofit on machines. The bellows can afterwards be closed with adhesive tape, Velcro tape or bonding. The higher compression of these types must be taken into consideration.

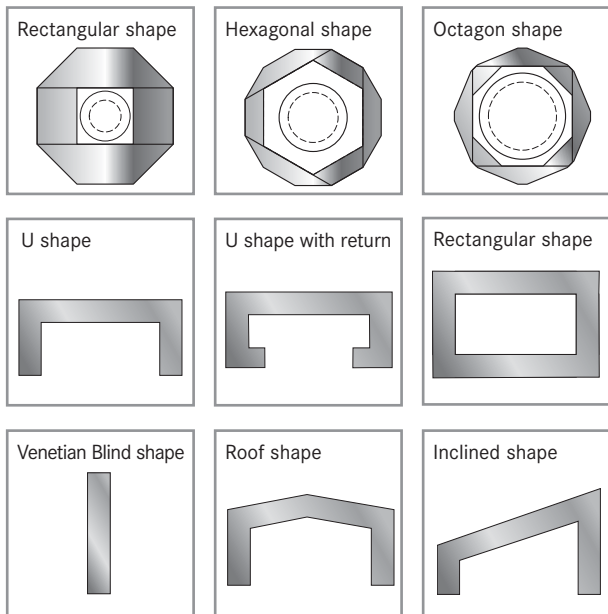

Range of available shapes

Polygonal section with support elements

This sectional view shows an example of a design solution for horizontal applications. Sub frames with guides or guide rings are used here to support the shaft or spindle. These additional guiding elements ensure that the LAMINAT bellows run smoothly and with less friction

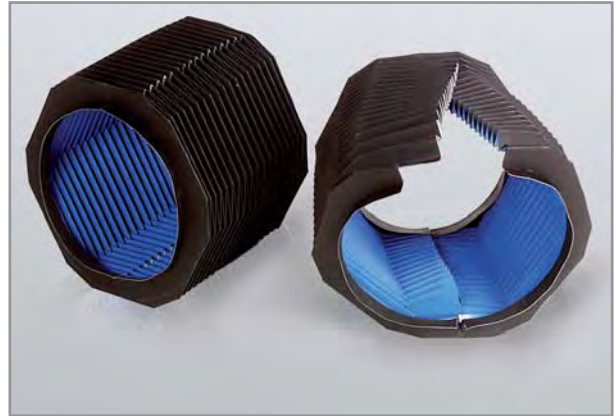

Split version for fast mounting or retrofitting

Characteristic

The stiffness of LAMINAT Bellows (standard designs) can be enhanced with an optional PVC frame or wire hoop in every second or third fold.

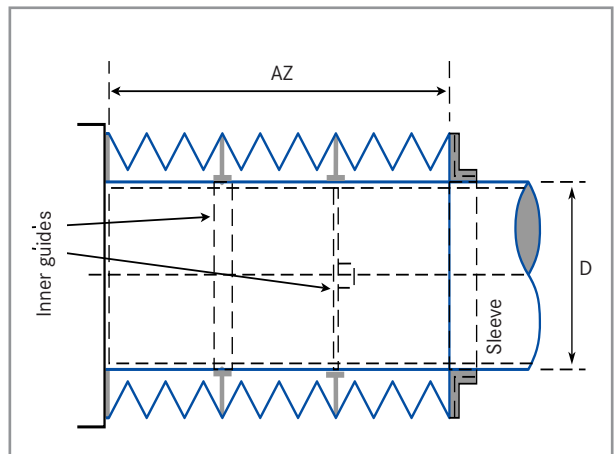

Sectional view of bellows with support elements

Furthermore they can be supported on special gliders or roller systems, recommend at speeds higher than 30 m/min. On the polygon sections, spacers and circular guide/support systems ensure the optimum gliding efficiency on columns, spindles and shafts. Also extension limiters assure consistent extension after high acceleration impacts.

Mounting

LAMINAT Bellows can be easily mounted with metal end frames, clip fasteners, velcro tapes, or sleeves with strap retainer (for polygonal sections only).

Closed designs require adequate ventilation. We offer optional punching with or without filter.

LAMINAT BELLOWS

02

SERVICE & QUALITY

Legend

| | |
|-----|---|
| FB | Width of the fold |
| FZD | Compression per fold, depending on material |
| FAZ | Extension per fold |

14

STANDARD BELLOWS

| FB | FAZ | FZD |
|------|-----|-----|
| 7,5 | 9 | 3 |
| 10 | 15 | 3 |
| 12.5 | 18 | 3 |
| 15 | 20 | 3 |
| 17.5 | 25 | 3 |
| 20 | 30 | 3 |
| 25 | 37 | 3.5 |
| 30 | 45 | 3.5 |
| 35 | 55 | 4 |
| 40 | 60 | 4 |
| 45 | 65 | 4 |
| 50 | 70 | 4 |

Standard folds

26

SPECIAL BELLOWS

32

BACKWALL SYSTEMS

38

GLADIATOR STEEL COVERS

46

ROLLER SYSTEMS

58

DURASPRING SPIRAL SPRINGS

68

WEAVING SYSTEMS

| FB | FAZ | FZD |
|------|-----|-----|
| 7,5 | 8 | 3 |
| 10 | 13 | 3 |
| 12.5 | 15 | 3 |
| 15 | 20 | 3 |
| 17.5 | 23 | 3 |
| 20 | 25 | 3 |
| 25 | 30 | 3.5 |
| 30 | 35 | 3.5 |
| 35 | 40 | 4 |
| 40 | 45 | 4 |
| 45 | 50 | 4 |
| 50 | 55 | 4 |

Alternating folds

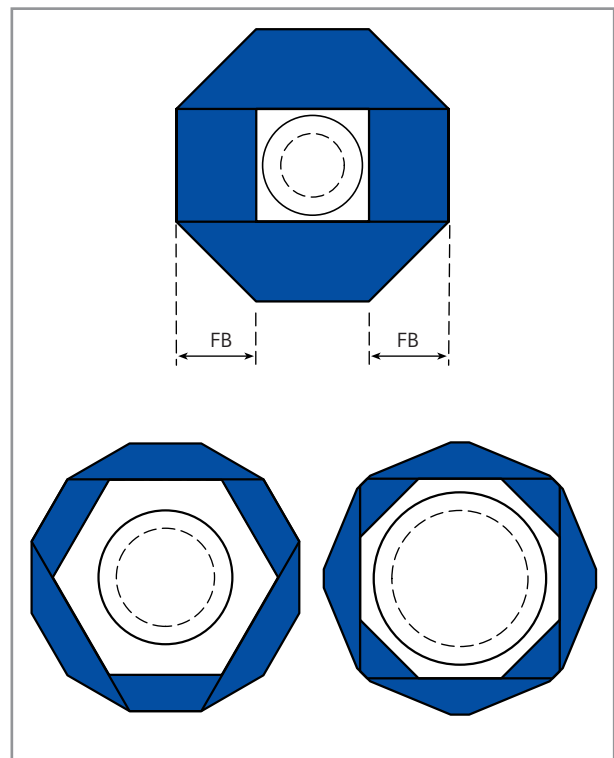

Alternating folds

CIRCULAR-STITCHED BELLOWS

The circular-stitched bellows consist of punched disks stitched inside and outside.

Stitching achieves particularly good shape stability and high transverse stiffness.



Circular stitched bellows

Material

Standard applications require material GN 807, and high temperature applications aluminium/glass fibre.

Circular-stitched bellows are extremely resistant and can even withstand impact from sharp edged chips, also in the smaller versions. They are suitable only to a limited extent as protection against liquids and oils.

Mounting position

Circular-stitched bellows can be used horizontally or vertically. Additional support and guide rings made of synthetics assure a uniform distance from the spindle and so increase operating life.

When with large extensions the stability of the bellows can be increased when a wire ring is installed in every fold.

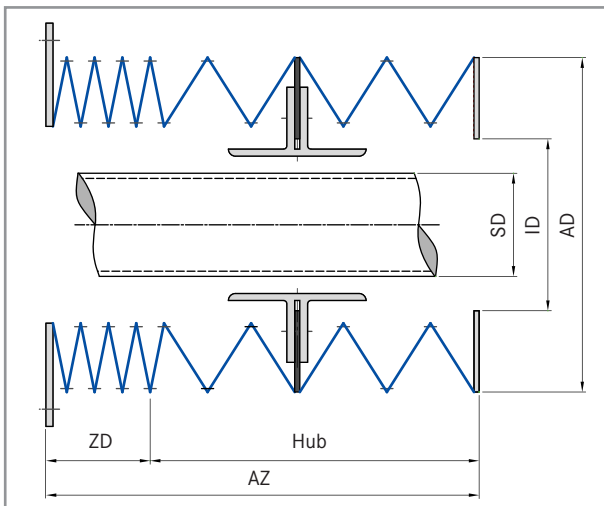

Sectional view: Circular stitched bellows

The usual connecting and mounting elements are metal frames, but sleeves are an alternative.

Design information

The correct bellow diameter should be about 10 mm larger than the part they are to protect. Use the following formula for measurements.

Design and Legend

$$\text{Extension} = (\text{Stroke} / \text{FStroke}) \times \text{FAZ} + 5$$

| | |
|---------|---------------------|
| AD | Outside diameter |
| FB | Fold width |
| ID | Inside diameter |
| FAZ | Fold extension |
| FZD | Fold compression |
| FStroke | Stroke per fold |
| SD | Diameter of spindle |

| HEMA Type | AD | ID | FB | FAZ | FZD | FStroke |
|-----------|-----|-----|------|-----|-----|---------|
| RF 50 | 52 | 25 | 12.5 | 10 | 2.5 | 7.5 |
| RF 72 | 72 | 33 | 19.5 | 18 | 2.5 | 15.5 |
| RF 85 | 85 | 45 | 20 | 18 | 2.5 | 15.5 |
| RF 95 | 95 | 53 | 21 | 18 | 2.5 | 15.5 |
| RF 100 | 100 | 63 | 18.5 | 18 | 2.5 | 15.5 |
| RF 120 | 120 | 82 | 19 | 18 | 2.5 | 15.5 |
| RF 122 | 122 | 76 | 23 | 15 | 2.5 | 12.5 |
| RF 130 | 130 | 90 | 20 | 18 | 2.5 | 15.5 |
| RF 135 | 135 | 85 | 25 | 15 | 2.5 | 12.5 |
| RF 140 | 140 | 100 | 19 | 18 | 2.5 | 15.5 |
| RF 145/1 | 145 | 93 | 26 | 15 | 2.5 | 12.5 |
| RF 145/2 | 145 | 105 | 20 | 18 | 2.5 | 15.5 |
| RF 150 | 150 | 110 | 20 | 18 | 2.5 | 15.5 |
| RF 160 | 160 | 112 | 24 | 18 | 2.5 | 15.5 |
| RF 170 | 170 | 125 | 22.5 | 18 | 2.5 | 15.5 |
| RF 180/1 | 180 | 132 | 24 | 20 | 2.5 | 17.5 |
| RF 180/2 | 180 | 141 | 19.5 | 18 | 2.5 | 15.5 |
| RF 190 | 190 | 150 | 20 | 18 | 2.5 | 15.5 |
| RF 200 | 200 | 152 | 24 | 18 | 2.5 | 15.5 |
| RF 220 | 220 | 170 | 25 | 18 | 2.5 | 15.5 |
| RF 235 | 235 | 190 | 22.5 | 18 | 2.5 | 15.5 |
| RF 245 | 245 | 200 | 22.5 | 20 | 2.5 | 17.5 |
| RF 260 | 260 | 202 | 29 | 18 | 2.5 | 15.5 |
| RF 266 | 266 | 216 | 25 | 20 | 2.5 | 17.5 |
| RF 300 | 300 | 250 | 25 | 18 | 2.5 | 15.5 |
| RF 365 | 365 | 320 | 22.5 | 18 | 2.5 | 15.5 |
| RF 400 | 400 | 340 | 30 | 20 | 2.5 | 17.5 |

SERVICE & QUALITY

02

STANDARD BELLOWS

15

SAU/MRAI BELLOWS

18

SPECIAL BELLOWS

26

BACKWALL SYSTEMS

32

GLADIATOR STEEL COVERS

38

ROLLER SYSTEMS

46

DURASPRING SPIRAL SPRINGS

58

VIEWING SYSTEMS

68

BELLOWS FOR JET CUTTING MACHINES

Modern jet cutting machines (with lasers, plasma or water) are fitted with bellows to protect the jet channel and the mechanical components such as spindles and guides.



Guided bellows for laser cutting

These types of bellows require a high level of tightness and long life.

Bellows for jet cutting machines are primarily made of self-extinguishing materials such as Preetex.

The materials selected have been extensively tested with various impact cycles.

At all stages from production to packaging and shipment our bellows are maintained in a particularly clean state and free of dust, e.g. with special packing.



Bellows in operation

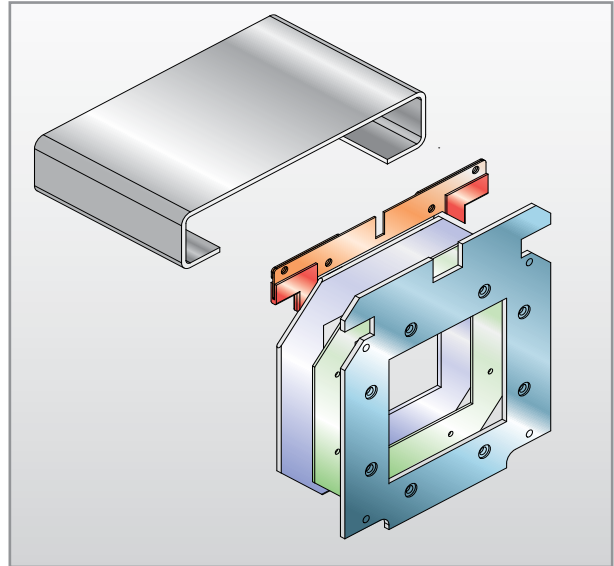

Structure of synthetic material frames and guiding frames

- High temperature resistance of bellow material
- No outgassing of materials
- Gas-tight for minimised flushing gas losses
- Superior clean state during production and shipment

Construction

For better stability the bellows used for jet cutting machines are fitted with stabilizing synthetic material frames.

These frames are customized to each guidance type, e.g. guiding bars. Normally these bellows are mounted with metal end frames.

Especially important is a separate guiding system that keeps the bellows material intact.

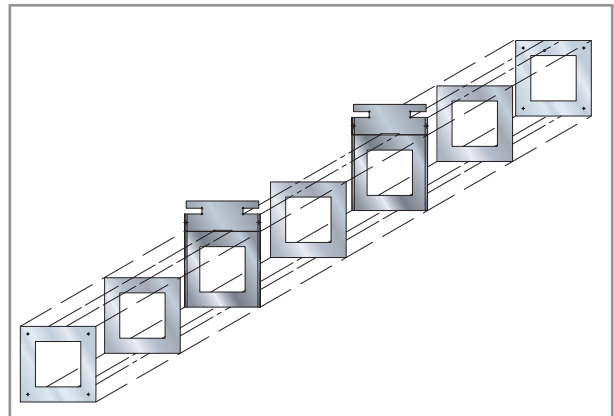

External guide for laser cutting bellows

BELLOWS FOR LINEAR GUIDES

Linear drives can be either retrofitted by the customer or fitted with bellows before they leave the factory. HEMA has specialised in this field and offers bellows tailored to the leading international manufacturers, e.g. INA, NSK, Schneeberger, Bosch-Rexroth, THK or NSK.

On the basis of precise type denominations the bellows and their guiding components can be manufactured correctly to size.

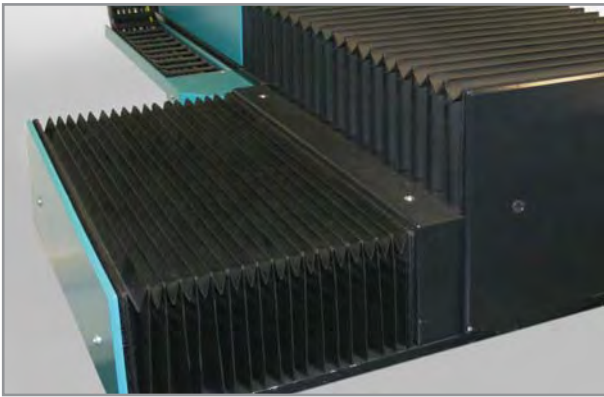

Example application

Material

Standard applications require PU coated materials, but heat resistant and self extinguishing materials are also available. For the best services and immediate replacements these bellows are also available as »endless versions« with 200 or more folds in total. The required dimensions can easily be configured by the customer.

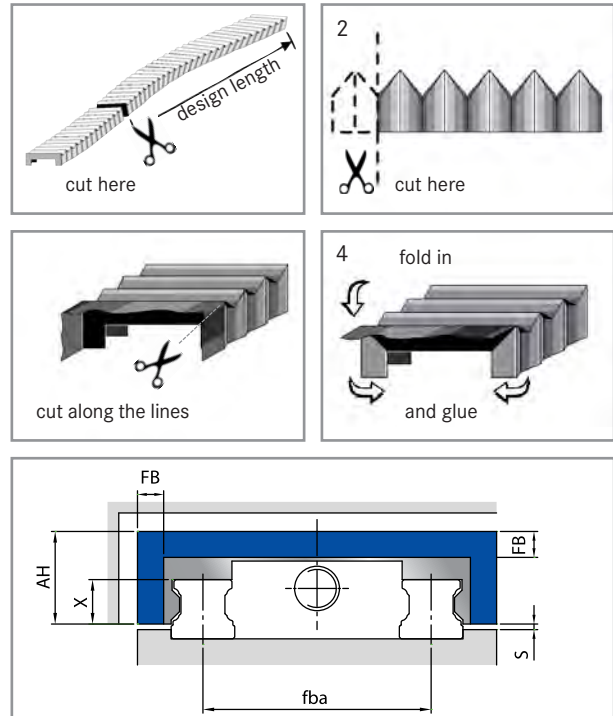

Legend

| | |
|-----|----------------------|
| FB | Fold width |
| FAZ | Extension per fold |
| fba | Width of guiding way |
| AH | Exterior height |
| X | Interior height |
| S | Play |

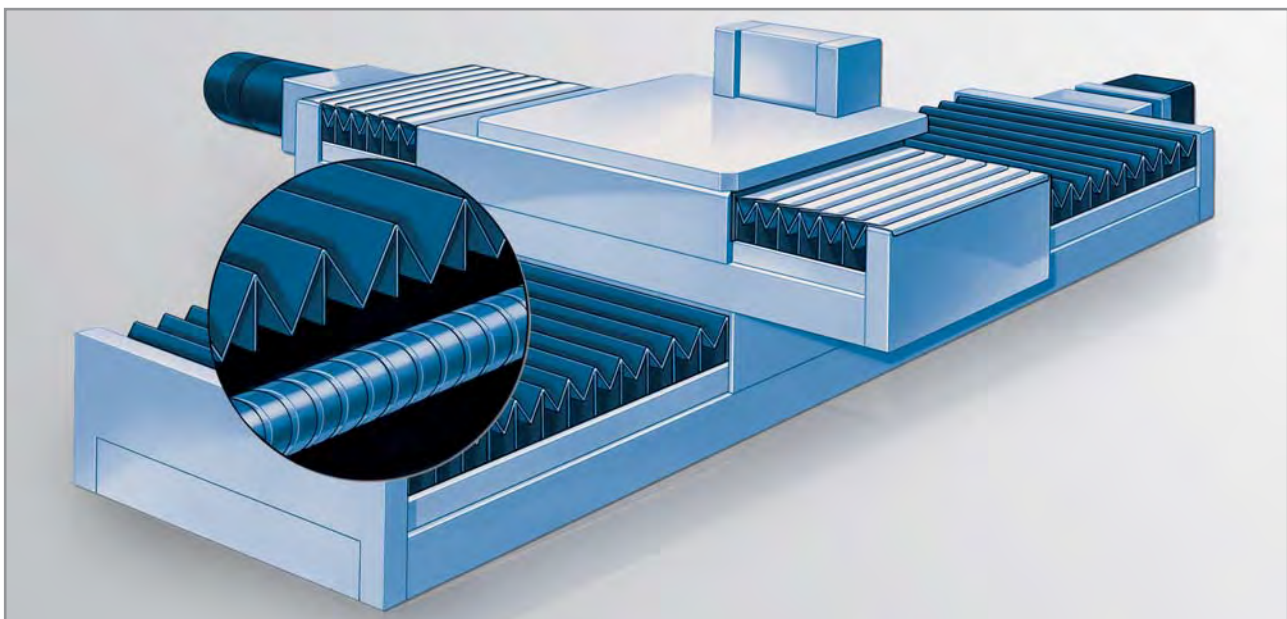

Diagram of an application